



Mounting instructions for ABT AEC VW Amarok V6

Table of contents

1 Hints	3
2 Information about electrical consumption	4
3 Scope of delivery.....	5
4 Preparations at the vehicle.....	8
5 Laying sensor wiring harness.....	9
6 AEC Assembly.....	12
7 AEC Installation.....	13
8 Completion.....	15
9 Overall view.....	16
10 Warning lamps.....	17

1 Hints

Mounting instructions for ABT AEC VW Amarok V6

Vehicles: VW Amarok 3,0 TDI MKB DDXC

Assembly time: approx. 60 minutes

Attention: To guarantee optimal function and security of the ABT AEC it is necessary to thoroughly read through the assembly instructions prior to work and to operate the installation as described.

Important steps to take before assembling the ABT AEC:

Before starting the installation, the error memory of the vehicle in which the AEC will be installed has to be read out.

In case of an error log entry:

- Please follow the manufacturer's instructions to resolve errors.
- After the rectification it is necessary to once again take a test drive of minimum 30 km.

Install the ABT AEC only into vehicles which are error-free at the time of installation.

2 Information about electrical consumption

Power upgrades provided by an AEC increase the electrical consumption of a vehicle. An additional current flows. Besides this, the total current is depending on the car type, the additional equipment or similar. In particular cases, a considerable higher power consumption is possible.

The total power consumption determines how often a vehicle can be started without recharging the battery. Furthermore, it depends on the age and charging condition of the battery as well as on the outside temperature. For vehicles which are used sporadically, it is generally recommended to recharge the battery periodically. Thus the battery's durability can be prolonged.





In case the vehicle is not in use for longer than one week, we recommend to replace the AEC with a bridge adapter. In doing so, an additional power consumption is prevented. Due to the adapter, the vehicle remains ready to start and is in its original state.





This bridge adapter can be purchased separately.



While staying abroad in areas where fuel quality is rather bad, we recommend to use the bridge adapter.

3 Scope of delivery

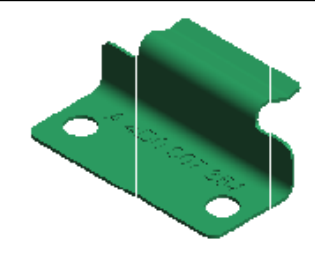
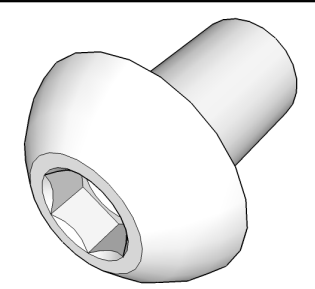
Please check the completeness of delivery before starting the installation. In case the delivery is incomplete, please contact ABT Sportsline GmbH.

Quantity	Picture	Description
1		ABT Engine Control
1		Wiring harness
1		"ABT Power" sticker
1		"ABT Information" sticker
1		ABT service book

Quantity	Picture	Description
1		"98 ROZ Super Plus" sticker (gas engine only)
12		Cable tie
2		Retaining clip 12 mm
4		Lens head screw M5 x 6
3		Plastic washer nut

Quantity	Picture	Description
4		Spring ring M5
1		AEC bracket

4 Preparations at the vehicle

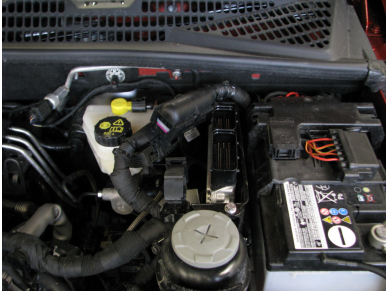

If available, remove anti-theft device.
Disconnect the standard wiring harness from the ECU.

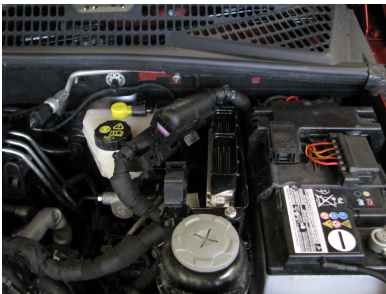

Connect the male multipoint connector of the AEC wiring harness with the standard wiring harness.



Connect the 91 pin plug of the AEC wiring harness with the standard ECU.

5 Laying sensor wiring harness



Disconnect the rail pressure sensor connector.



Connect the AEC wiring harness connector which is marked "Raildruck" to the sensor and connect the AEC harness connector to the previously unplugged connector.



Disconnect the boost pressure sensor connector.

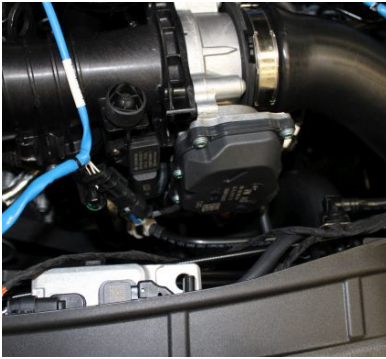

Connect the AEC wiring harness connector which is marked "Ladedruck" to the sensor and connect the AEC wiring harness connector to the previously unplugged connector.



Disconnect the plug of the speed sensor camshaft.



Connect the AEC wiring harness connector which is marked "Hallgeber" to the sensor.
Connect the AEC wiring harness connector to the previously removed plug.



Route the "AEC" connector of the AEC wiring harness towards the interior air intake.

6 AEC Assembly



Attach the retaining clips with screws and spring washers at the AEC bracket.



Put the AEC into the bracket and tighten the screws.

7 AEC Installation

Connect the plugs from the AEC wiring harness which are marked with "AEC" with the AEC.

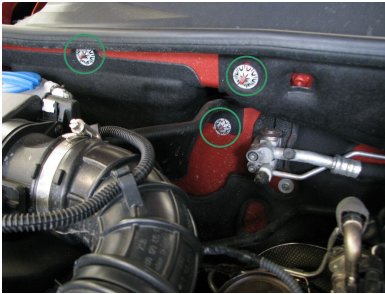

The AEC bracket is attached at the marked screws.
Before you start to fix the bracket, connect the wiring harness with the AEC.

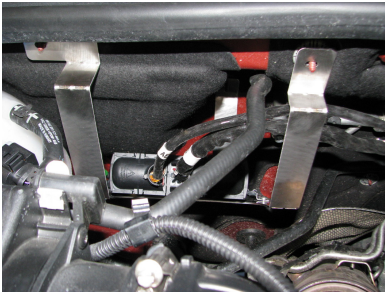

Put the bracket on the three fixing points.

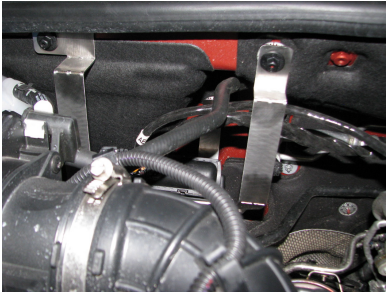

Fix the AEC bracket with the plastic washer nuts.



Attach and fix the wiring harness and the male multipoint connector with the cable ties.

Attention: Keep attention that the cables do not touch hot devices.

8 Completion

Read out the error memory and delete if necessary.

Start the engine and take a test drive.

Attach the sticker "ABT Power" to the engine cover and a sticker "ABT Information" on the lock carrier.

Only gasoline engines: Apply the sticker "98 ROZ Super Plus" in the fuel filler flap.

Hint: The AEC can be left built in for manufacturer service updates. The communication with the tester is not affected by the AEC.

If the MIL-lamp and the EPC-lamp is blinking by turns, there is an error in the ABT AEC. Then please contact ABT Sportsline GmbH.

9 Overall view



10 Warning lamps



Malfunktion Indicator Lamp (MIL)



Electronic Power Control (EPC)



Control lamp "Preheat"

ABT Sportsline GmbH

Johann-Abt-Str. 2

D-87437 Kempten / Allgäu

Phone: +49 (0)831 / 57140 - 0

Fax: +49 (0)831 / 72666

Email: info@abt-sportsline.de

www.abt-sportsline.de