



Assembly Instructions

ABT-AEC for PL 57
RHD

- Audi A6
- Audi A7

Assembly Instructions

ABT-AEC for PL 57 **RHD**

Car model: Audi A6, A7

Assembly time: approx. 90 min

Attention: To guarantee optimal function and security of the ABT AEC it is necessary to thoroughly read through the assembly instructions prior to work and to operate the installation as described.

Important steps to take before assembling the ABT AEC

Before starting the installation, the error memory of the vehicle in which the AEC will be installed has to be read out.

Error log entry:

- Please follow the manufacturer's instructions to resolve errors.
- After the rectification it is necessary to once again take a test drive of minimum 30 km.

It is only allowed to install the ABT AEC into vehicles which are error-free at the time of installation.



TABLE OF CONTENTS

1. INFORMATION ABOUT ELECTRICAL CONSUMPTION.....	4
2. SCOPE OF DELIVERY	5
3. PREPERATIONS AT THE VEHICLE.....	8
4. AEC ASSEMBLY	9
5. AEC INSTALLATION	10
6. COMPLETION	13
7. WARNING LAMPS	14







1. Information about electrical consumption

Power upgrades provided by an AEC increase the electrical consumption of a vehicle. An additional electric current flows. Besides this, the total current is depending on the car type, the additional equipment or similar. In particular cases, a considerable higher power consumption is possible. The total power consumption determines how often a vehicle can be started without recharging the battery. Furthermore, it depends on the age and charging condition of the battery as well as on the outside temperature. For vehicles which are used only sporadically, it is generally recommended to recharge the battery periodically. Thus the battery's durability can be prolonged.

In case the vehicle is not in use for longer than one week, we recommend to replace the AEC with a bridge adapter. In doing so, an additional power consumption is prevented. Due to the adapter, the vehicle remains ready to start and is in its original state. This bridge adapter can be purchased separately. While staying abroad, in areas where fuel quality is rather bad, we recommend to use the bridge adapter.





2. Scope of delivery



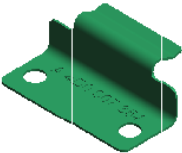

Please check for completeness of delivery before starting the installation. In case the delivery is incomplete, please contact our service team at ABT Sportsline.

amount	picture	description
1		ABT Engine Control
1		Wiring harness
1		“ABT power” sticker
1		ABT information sticker

Assembly Instructions
ABT-AEC
PL 57 **RHD**

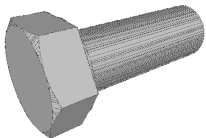

1		ABT service book
1		„98 ROZ Super Plus“ sticker (gas engine only)
10		Cable Tie
2		Retaining clip 12 mm
4		Lens head screw M5 x 6
1		Lens head screw M5 x 16

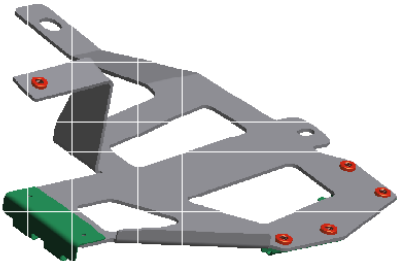
1		Hexagon bolt BSF 7/16 x 1"
5		Spring ring M5
1		Spring ring M12
5		Flat washers M5
1		Flat washers M12
1		Adapter plate

3. Preparations at the vehicle



Remove the water tank cover.



4. AEC assembly



Attach the AEC with clips, screws and spring rings to the bracket.

5. AEC Installation

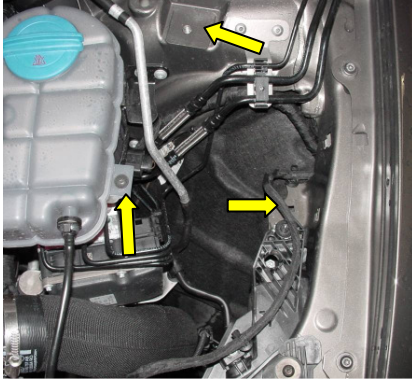

Fix the AEC with the mounted plate behind the left headlamp. The arrows show the three attachment points.

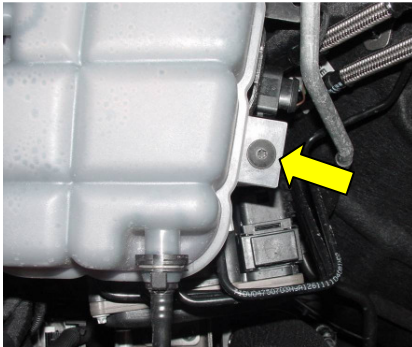

Remove the marked screw from the coolant container.

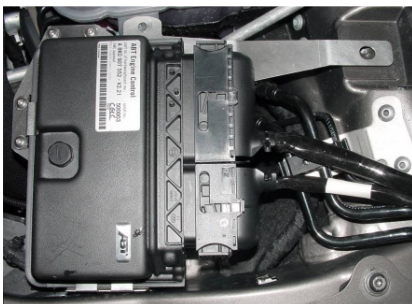

Fix the left foot from the plate under the vehicle body sheet. The other arms rest on the attachment points. Don't tighten the screws, yet.

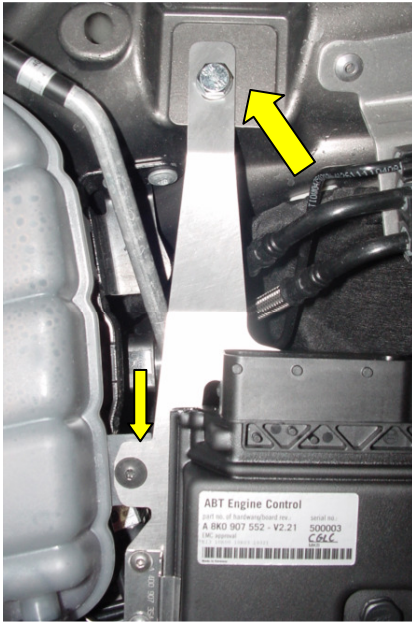

Collar the screw from the coolant container again.
Fix the arm (at the top of the picture) with the inch screw, flat washer and lock washer at the marked point.

ATTENTION: It is an inch screw. Don't use a metric screw. Use a 15 mm screw wrench.

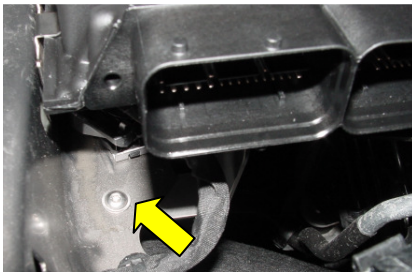

Fix the third point with the M5 x 16 screw, lock washer and flat washer.

Tighten the screws.

The AEC-holder must not scratch on the car body.

Connect the male multipoint connector to the serial plugs and the unmarked plugs to the engine control unit..

Run the cable as shown in the figure and fix with several cable ties.

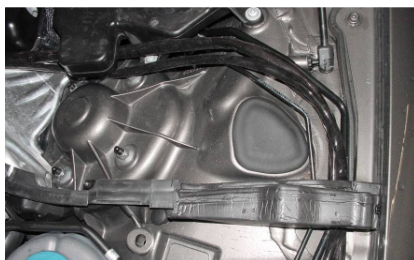

Place the cable along the brake system pipe.
Fix the cable with the cable ties.

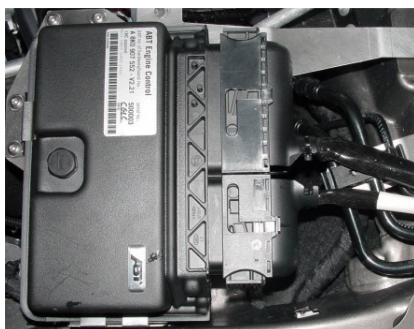

Connect the plugs marked with "AEC" to the AEC

Note: To adjust the headlights, the AEC has to be removed from the bracket. Then the maintenance unit is accessible.



6. Completion

Reinstall all serial parts to the vehicle.

Read out the error memory and delete it if necessary.

Take a test drive.

Attach the sticker "Abt Power" to the engine cover and the information sticker to the lock carrier.

Only gasoline engines: Apply the '98 ROZ Super Plus' sticker in the fuel filler flap.

If the MIL-lamp and EPC-lamp are blinking by turns, there is an error in the ABT AEC. Then please contact ABT Sportsline.

7. Warning lamps

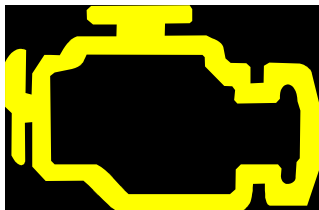

Malfunction-Indicator-Lamp (MIL)



Electronic Power Control (EPC)

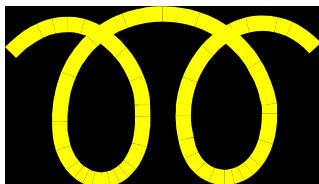

Control lamp "Preheat"

ABT Sportsline GmbH
Johann-Abt-Str. 2
D-87437 Kempten / Allgäu
Tel.: +49 (0)831 / 5 71 40-0
Fax: +49 (0)831 / 7 26 66
info@abt-sportsline.de
www.abt-sportsline.de